



# LD Packages

Discover the value of Graco LD™ Series Pumps



PROVEN QUALITY. LEADING TECHNOLOGY.

# Index

## LD Series

LD Air-Powered Pumps .....	p. 4 - 6
LD Meters .....	p. 7
LD Enclosed Hose Reels .....	p. 8

## Oil Packages

### **Oil Pumps and Packages without Reels**

3:1 Bare Oil Pumps .....	p. 9
5:1 Bare Oil Pumps .....	p. 9
3:1 Oil Wall Packages .....	p. 10
5:1 Oil Wall Packages .....	p. 10
3:1 Oil Drum Mount Packages .....	p. 11
5:1 Oil Drum Mount Packages .....	p. 12

### **Oil IBC Packages without Reels**

3:1 Oil Wall Mount Packages .....	p. 13
5:1 Oil Wall Mount Packages .....	p. 13

### **Oil IBC Packages with Reels**

3:1 Oil Top Mount Packages .....	p. 14
5:1 Oil Top Mount Packages .....	p. 15
3:1 Oil Side Mount Packages .....	p. 16
5:1 Oil Side Mount Packages .....	p. 17

### **Oil Cart Mount Packages without Reels**

3:1 Oil Cart Mount Packages .....	p. 18
5:1 Oil Cart Mount Packages .....	p. 19

### **Oil Cart Mount Packages with Reels**

3:1 Oil Cart Mount Packages .....	p. 20
5:1 Oil Cart Mount Packages .....	p. 21

## Grease Packages

### **Grease Pumps and Packages**

Bare Grease Pumps .....	p. 22
50:1 Grease Drum Packages - 16/20kg .....	p. 22
50:1 Grease Drum Packages - 55/60kg .....	p. 22
50:1 Grease Drum Packages - 180kg .....	p. 23

### **Grease Cart Mount Packages**

50:1 Grease Cart Mount Packages - 55kg / 60kg .....	p. 24
50:1 Grease Cart Mount Packages - 180kg .....	p. 25

## Accessories LD Packages

Drum Covers .....	p. 26
Follower Plates .....	p. 26
Suction Kits .....	p. 26
Hose and Fitting Kits - Oil (NON CE) .....	p. 26
Hose and Fitting Kits - Oil (CE) .....	p. 26
Tote Mount Accessories .....	p. 27
Carts .....	p. 27
Hose and Fittings Kits - Grease (NON CE) .....	p. 27
Hose and Fittings Kits - Grease (CE) .....	p. 27
Mounting Hardware .....	p. 27
Bung Adapter .....	p. 27

# Performance Runs in the Family

## State-of-the-Art Design

Each product in the LD family has innovative features built-in, plus advanced technologies designed to save you money and provide reliable performance and long life at a competitive price.

## More Configurations

Choose drum, tote or wall mount applications with multiple meter, pump and reel choices

## Industry Leading Warranty

Graco offers one of the best warranties in the business—5 years on all our LD Series family products.\*

## ATEX Approved

High Quality pumps for various environment.

\* Two years on LD Meter electronics



## Everything you need, right out of the box

Choose from a variety of dispensing solutions. From the economical drum package to the high-performance tote packages, every solution is designed with the highest quality components for trouble-free operation.



# LD Air-Powered Pumps

Only Graco can give you the field-proven performance found in the famous FireBall® pump for a solution that works as hard as you. Fast repairs, flexible configuration, industry leading warranty, and so many other field proven features are built-in—all at a competitive price.

**Loaded with high performance technologies.**

## **LD 3:1 Pump**

Medium pressure, high flow applications

## **LD 5:1 Pump**

High pressure, medium flow for cold temperature or long run applications

## **LD 50:1 Pump**

High pressure grease to 7500 psi

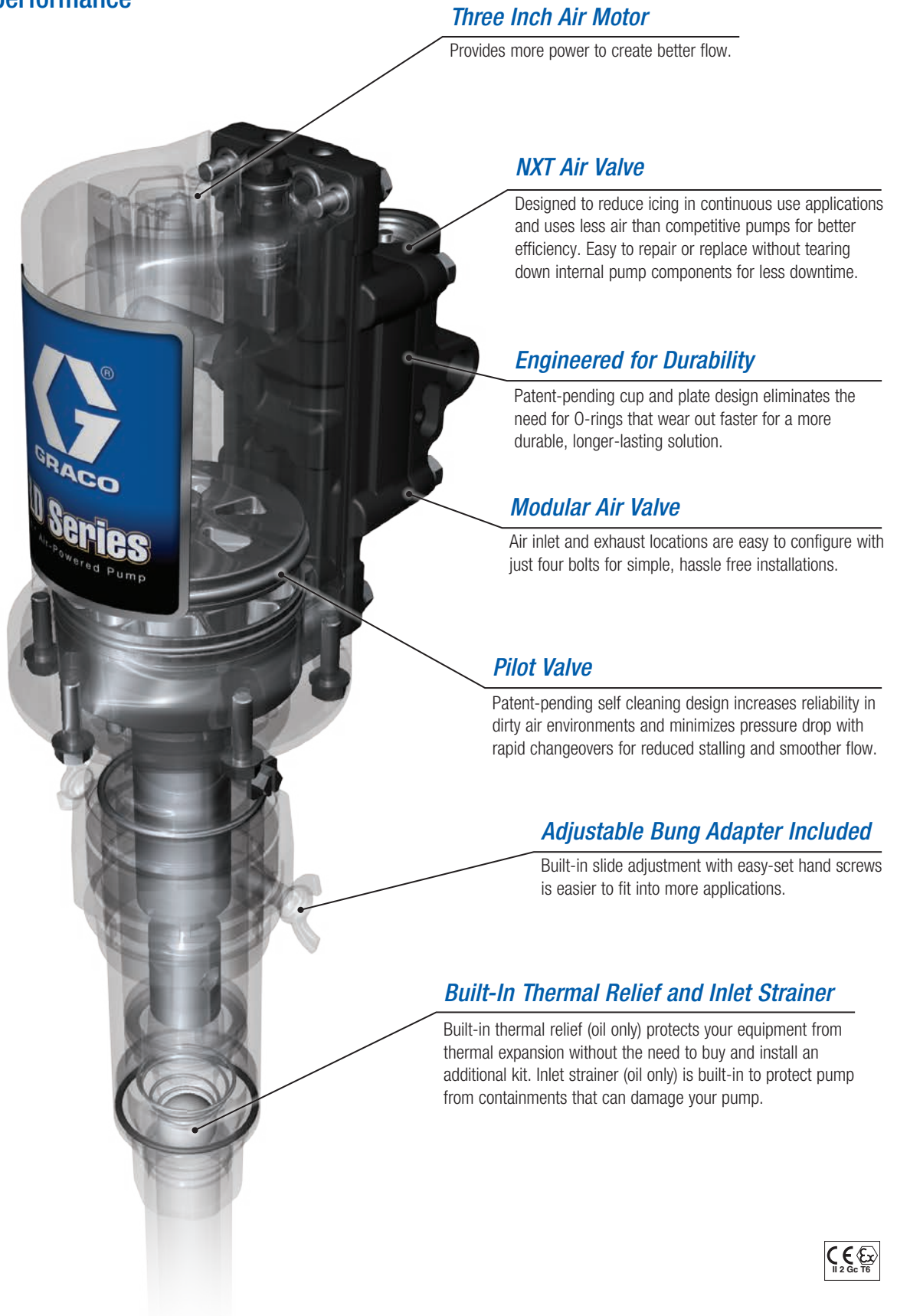

### **Three Inch Air Motor**

Provides more power to create better flow.

### **NXT Air Valve**

Designed to reduce icing in continuous use applications and uses less air than competitive pumps for better efficiency. Easy to repair or replace without tearing down internal pump components for less downtime.

### **Engineered for Durability**

Patent-pending cup and plate design eliminates the need for O-rings that wear out faster for a more durable, longer-lasting solution.

### **Modular Air Valve**

Air inlet and exhaust locations are easy to configure with just four bolts for simple, hassle free installations.

### **Pilot Valve**

Patent-pending self cleaning design increases reliability in dirty air environments and minimizes pressure drop with rapid changeovers for reduced stalling and smoother flow.

### **Adjustable Bung Adapter Included**

Built-in slide adjustment with easy-set hand screws is easier to fit into more applications.

### **Built-In Thermal Relief and Inlet Strainer**

Built-in thermal relief (oil only) protects your equipment from thermal expansion without the need to buy and install an additional kit. Inlet strainer (oil only) is built-in to protect pump from contaminants that can damage your pump.

# Technical specifications

## LD Series 3:1 Oil Pump

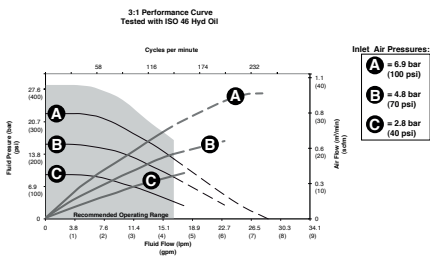

## LD Series 5:1 Oil Pump

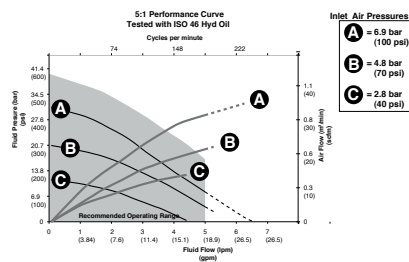

## LD Series 50:1 Grease Pump

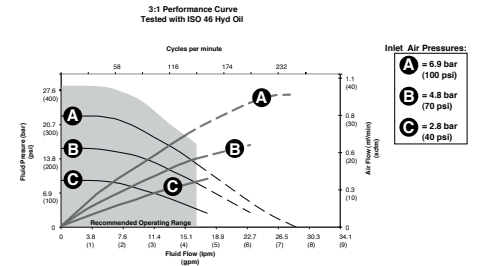

Tested with ISO 46 Hydraulic Oil. Inlet air pressures: A = 6.9 bar (100 psi) B = 4.8 bar (70 psi) C = 2.8 bar (40 psi).



	3:1 LD OIL PUMP	5:1 LD OIL PUMP	50:1 LD GREASE PUMP
Maximum Fluid Working Pressure	31 bar (450 psi, 3.10MPa)	51.7 bar (750 psi, 5.17MP a)	517 bar (7500 psi, 51.7 MPa)
Fluid Pressure Ratio	3:1	5:1	50:1
Suction Lift (feet of oil)	10	10	—
Air Operation Range	1.37 to 10.3 bar (20 to 150 psi)	1.37 to 10.3 bar (20 to 150 psi)	1.37 to 10.3 bar (20 to 150 psi)
Recommended Air Pressure (for optimum life)	< 8.6 bar (125 psi, 0.86 MPa)	< 8.6 bar (125 psi, 0.86 MPa)	< 8.6 bar (125 psi, 0.86 MPa)
Max Recommended Pump Speed	120 cycles per minute	180 cycle per minute	120 cycle per minute
Cycles Per l/kg (Gallon/pound)	7 cycles per liter (29 cycles per gallon)	10 cycles per liter (37 cycles per gallon)	103 cycles per kg (47 cycles per pound)
Recommended Pump Speed (for maximum life)	75 cycles per minute or lower	75 cycles per minute or lower	60 cycles per minute or lower
Wetted Parts	Zinc plated carbon, steel, aluminum, nitrile, polyurethane, nickel plated aluminum		Steel, brass, nitrile rubber, polyurethane, UHMWPE, acetal
Sound Pressure Level	72.9 dB(a)	72.9 dB(a)	72.9 dB(a)
Sound Power Level	82 dB(a)	82 dB(a)	82 dB(a)
Approximate Weight	3.2 kg (7 pounds)	3.5 kg (7.7 pounds)	16 kg drum - 5.1 kg, 54 kg drum - 6.8 kg, 181 kg drum - 7.7 kg
Air Inlet	1/4"	1/4"	1/4"
Fluid Inlet	1"	1"	Priming Piston
Fluid Outlet	1/2"	1/2"	1/4"
Free Flow*	34 lpm	25 lpm	1,87 kg/min

\*Free flow at 10.3 bar (150 psi) air inlet pressure, using SAE 20 oil at 21 °C (70° F)

## Technical specifications

### Dimensions

Model	L Length	O Overall Length
Universal Pump Only	175 mm (6.9 in)	406 mm (16 in)
Multi*	1076 mm (42.4 in)	1307 mm (51.5 in)
Drum	907 mm (35.7 in)	1138 mm (44.8 in)
Tote	1087 mm (42.8 in)	1318 mm (51.9 in)

- a = 1/4 inch air inlet
- b = ground screw
- c = 2 inch npt bung adapter
- d = 1 inch fluid inlet
- e = 1/2 inch fluid outlet

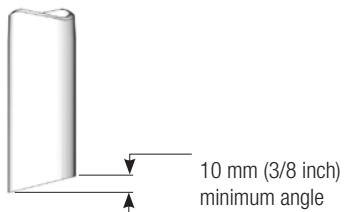

\* Multi down tube is angle cut to the desired length as required

LD Series  
3:1/5:1 Oil

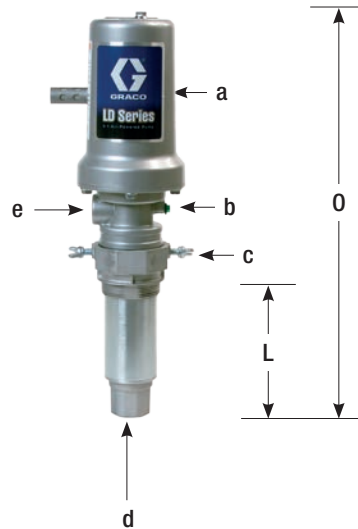

LD Series  
3:1/5:1 Oil Multi/Drum/Tote

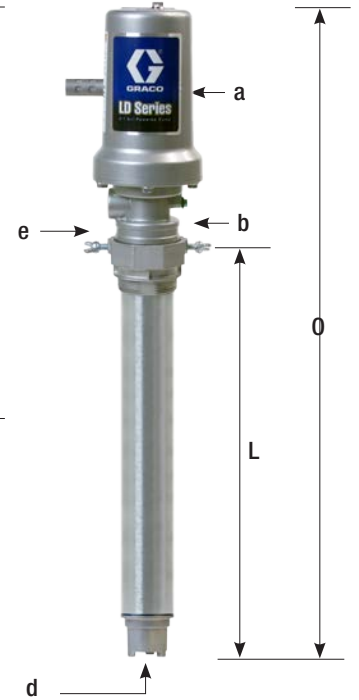

Model	L Length	O Overall Length
16 kg Drum	370 mm (14.5 in)	600 mm (23.6 in)
54 kg Drum	715 mm (28.1 in)	945 mm (37.2 in)
181 kg Drum	915 mm (36 in)	1145 mm (45 in)

LD Series  
16 kg Drum

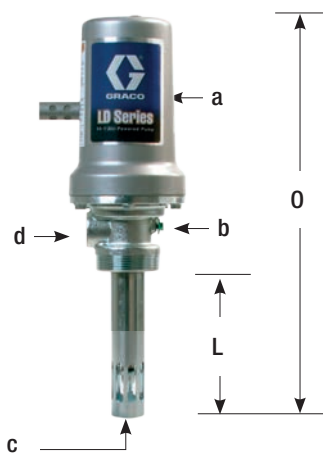

LD Series  
54 kg Drum

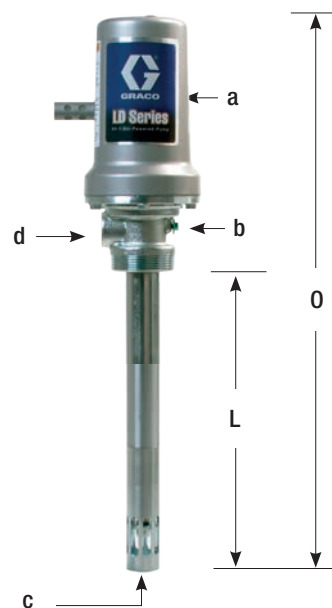

LD Series  
181 kg Drum

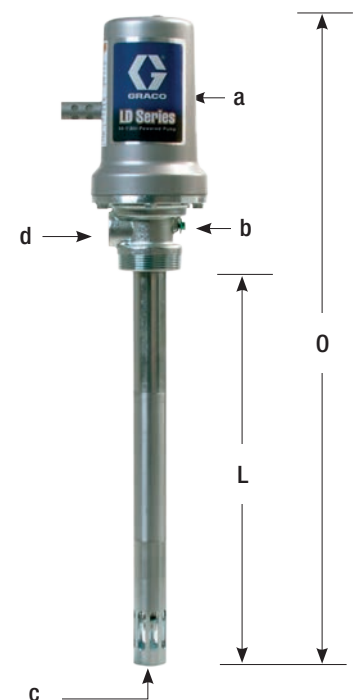

- a = 1/4 inch air inlet
- b = ground screw
- c = priming piston
- d = 1/4 inch fluid outlet

# LD Meters

## Technical specifications

### LDM5 Manual Dispense Meter



#### Two Models to Choose From

- LDM5 with inlet boot, trigger guard and rigid extension with thermal compensating nozzle
- LDM5 with flexible extension and automatic nozzle

### LDP5 Preset Dispense Meter



#### Two Models to Choose From

- LDP5 preset dispense model with inlet boot, trigger guard and rigid extension with thermal compensating nozzle
- LDP5 preset dispense model with flexible extension and automatic nozzle

### Fluid Inlet Screen

- Replaceable internal inlet screen protects meter from contaminants

### Fluid Extension Kits

- Standard rigid extension kit and automatic thermal compensating nozzle
- Optional flexible and gear lube extensions available

### Operator Controls

- Easy to read LCD display with durable switches for long life

### Meter Body

- Rugged engineered material for superior impact resistance and long life
- Ergonomically-designed handle for optimum comfort

### Trigger

- Two-finger trigger
- LDP5 models have latching trigger

### Trigger Guard and Boot

- Protects finishes from scratching
- Black boot and guard is standard, also available in red, blue, green and yellow

LDP5 Preset Model Shown

Flow range <sup>(1)</sup>	0.4 to 19 lpm (0.1 to 5 gpm)
Max. working pressure	69 bar (1000 psi)
Units of measure	Quarts, pints, gallons, liters (factory set to quarts)
Weight	1.36 kg (3 lbs)
Inlet	3/8"
Outlet	1/2 in npt
Operating temperature	0°C to 49°C (32°F to 120°F)
Storage temperature	-34°C to -49°C (-30°F to 120°F)
Battery	9V alkaline
Battery life	LDP5 - six months with alkaline LDM5 - one year with alkaline

Wetted Parts	sst, nitrile rubber, zinc, cs, lcp
Meter pressure loss <sup>(1)</sup>	6.21 bar @ 18.9 lpm (90 psi @ 5 gpm)
Accuracy <sup>(2)</sup>	±0.5%
Dimensions (w/o extension)	28cm x 8.3cm x 8.3cm (11 in L x 3.25 in W x 3.25 in H)
Maximum totalizer	99,999 gallons or liters
Max. recorded dispense	999.99 units
Max preset volume	99.99 units (LDP5 only)
Warranty	Two years
Instruction manual	312668

2. @ 9.5 lpm (2.5 gpm) @ 21°C (70°F) with 10 wt. oil and 3.8 l (1 gal) dispensed. May require re-calibration. Out-of-box accuracy ±1.25%.

1. Tested in 10W oil at 70°F. Flow rates vary with fluid pressure, temperature, viscosity, inlet fitting and nozzle type.



# LD Enclosed Hose Reels

## Technical Specifications

### FEATURES

- Designed for light-duty applications
- Enclosed for safety and protection, extends hose life
- Flexible mounting options—hang on wall or ceiling; bench, table or tank top-mount options available
- Full-flow swivel maximizes fluid flow with minimal pressure drop
- Easy spring tension adjustment—increase or decrease pressure spring tension while reel is pressurized

### DIMENSIONS

#### LD SERIES ENCLOSED HOSE REELS

<b>A</b>	180 mm (7.1 in)
<b>B</b>	585 mm (23.0 in)
<b>C</b>	470 mm (18.5 in)
<b>D</b>	650 mm (25.6 in)

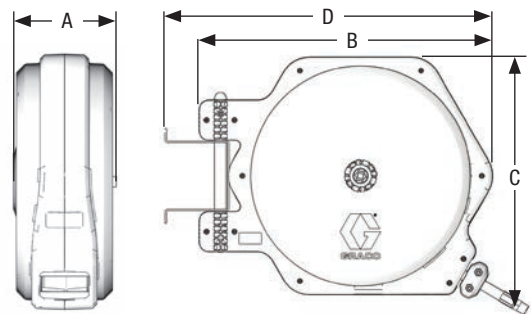

*Ceiling/Wall Swivel Mount  
(standard)*



*Ceiling/Wall Stationary Mount  
(optional)*



*Tote, Bench or Wall Mount Post  
(optional)*

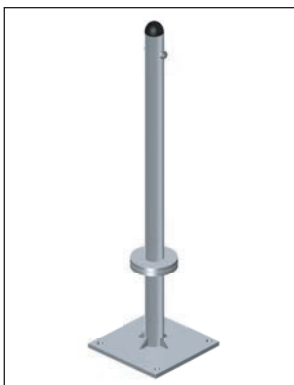

*Tote, Bench or Wall Mount Post  
24C772*



*Ceiling/Wall Stationary Bracket  
24E506*



*Hose Inlet Kit for  
LD enclosed reels*



# Oil Pumps and Packages WITHOUT Reels

## 3:1 BARE OIL PUMPS

BSPP	BSPT	NPT	DESCRIPTION
24G577	24G578	24G576	LD Pump, 3:1 Universal with bung adapter
24G580	24G581	24G579	LD Pump, 3:1 Pump - Multi-length
24G583	24G584	24G582	LD Pump, 3:1 Pump - 200L drum
24G586	24G587	24G585	LD Pump, 3:1 Pump - 1040 liter IBC



## 5:1 BARE OIL PUMPS

BSPP	BSPT	NPT	DESCRIPTION
24G589	24G590	24G588	LD Pump, 5:1 Universal with bung adapter
24G592	24G593	24G591	LD Pump, 5:1 Pump Multi-length
24G595	24G596	24G594	LD Pump, 5:1 Pump 200L drum
24G598	24G599	24G597	LD Pump, 5:1 Pump - 1040 liter IBC



### 3:1 OIL WALL PACKAGES

→ → → 200L Drum - No Meter - No Reel

BSPB	BSPT	NPT	DESCRIPTION	
<b>24H690</b>	<b>24H691</b>	<b>24H689</b>		<b>NON CE</b>
Includes:				
24G577	24G578	24G576	Universal oil pump 3:1	
24F936	24F937	24F935	940mm Down tube with 2m suction hose	
24F910	24F910	24F910	Wall mount bracket	
<b>24H693</b>	<b>24H694</b>	<b>24H692</b>		<b>CE</b>
Includes:				
24G577	24G578	24G576	Universal oil pump 3:1	
24F936	24F937	24F935	940mm Down tube with 2m suction hose	
24F910	24F910	24F910	Wall mount bracket	
125041	125041	110223	2-way vented valve	
24H419	24H419	24H420	Air pressure regulator	
24J378	24J378	24J378	Accessory kit	

This package is for use with drums. The wall mounted pump and the suction assembly allows a fast and clean drum replacement

### 5:1 OIL WALL PACKAGES

→ → → 200L Drum - No Meter - No Reel

BSPB	BSPT	NPT	DESCRIPTION	
<b>24H837</b>	<b>24H838</b>	<b>24H836</b>		<b>NON CE</b>
Includes:				
24G589	24G590	24G588	Universal oil pump 5:1	
24F936	24F937	24F935	940mm Down tube with 2m suction hose	
24F910	24F910	24F910	Wall mount bracket	
<b>24H840</b>	<b>24H841</b>	<b>24H839</b>		<b>CE</b>
Includes:				
24G589	24G590	24G588	Universal oil pump 5:1	
24F936	24F937	24F935	940mm Down tube with 2m suction hose	
24F910	24F910	24F910	Wall mount bracket	
125041	125041	110223	2-way vented valve	
24H419	24H419	24H420	Air pressure regulator	
24J379	24J379	24J379	Accessory kit	



CE version shown

## 3:1 OIL DRUM MOUNT PACKAGES

→ → → Multi-length - No Reel - **NON CE**

BSPP	BSPT	NPT	DESCRIPTION
<b>24H803</b>	<b>24H807</b>	<b>24H799</b>	<b>LDM5 FLEX METER</b>
Includes:			
24G577	24G578	24G576	Universal oil pump 3:1
24H861	24H860	24H859	Fluid hose kit
24F948	24F949	16F878	PVC Down tube
24F887	24F881	255751	LDM5 manual meter with flexible extension
<b>24H804</b>	<b>24H808</b>	<b>24H800</b>	<b>LDM5 RIGID METER</b>
Includes: idem as 24H803, 24H807, 24H799 but with			
24F888	24F882	256215	LDM5 manual meter with rigid extension
<b>24H805</b>	<b>24H809</b>	<b>24H801</b>	<b>LDP5 FLEX METER</b>
Includes: idem as 24H803, 24H807, 24H799 but with			
24F889	24F883	255277	LDP5 preset meter with flexible extension
<b>24H806</b>	<b>24H810</b>	<b>24H802</b>	<b>LDP5 RIGID METER</b>
Includes: idem as 24H803, 24H807, 24H799 but with			
24F890	24F884	256216	LDP5 preset meter with rigid extension

→ → → Multi-length - No Reel - **CE**

BSPP	BSPT	NPT	DESCRIPTION
<b>24H815</b>	<b>24H819</b>	<b>24H811</b>	<b>LDM5 FLEX METER</b>
Includes:			
24G577	24G578	24G576	Universal oil pump 3:1
24H610	24H609	24H608	Fluid hose kit
24F948	24F949	16F878	PVC Down tube
24F887	24F881	255751	LDM5 manual meter with flexible extension
125041	125041	110223	2-way vented valve
24H419	24H419	24H420	Air pressure regulator
24J379	24J379	24J379	Accessory kit
<b>24H816</b>	<b>24H820</b>	<b>24H812</b>	<b>LDM5 RIGID METER</b>
Includes: idem as 24H815, 24H819, 24H811 but with			
24F888	24F882	256215	LDM5 manual meter with rigid extension
<b>24H817</b>	<b>24H821</b>	<b>24H813</b>	<b>LDP5 FLEX METER</b>
Includes: idem as 24H815, 24H819, 24H811 but with			
24F889	24F883	255277	LDP5 preset meter with flexible extension
<b>24H818</b>	<b>24H822</b>	<b>24H814</b>	<b>LDP5 RIGID METER</b>
Includes:			
24F890	24F884	256216	LDP5 preset meter with rigid extension



CE version shown

## 5:1 OIL DRUM MOUNT PACKAGES

→ → → Multi-length - No Reel - **NON CE**

BSPB	BSPT	NPT	DESCRIPTION
<b>24H968</b>	<b>24H972</b>	<b>24H964</b>	<b>LDM5 FLEX METER</b>
Includes:			
24G589	24G590	24G588	Universal oil pump 5:1
24H861	24H860	24H859	Fluid hose kit
16F948	16F949	16F878	PVC Down tube
24F887	24F881	255751	LDM5 manual meter with flexible extension
<b>24H969</b>	<b>24H973</b>	<b>24H965</b>	<b>LDM5 RIGID METER</b>
Includes: idem as 24H968, 24H972, 24H964 but with			
24F888	24F882	256215	LDM5 manual meter with rigid extension
<b>24H970</b>	<b>24H974</b>	<b>24H966</b>	<b>LDP5 FLEX METER</b>
Includes: idem as 24H968, 24H972, 24H964 but with			
24F889	24F883	255277	LDP5 preset meter with flexible extension
<b>24H971</b>	<b>24H975</b>	<b>24H967</b>	<b>LDP5 RIGID METER</b>
Includes: idem as 24H968, 24H972, 24H964 but with			
24F890	24F884	256216	LDP5 preset meter with rigid extension

→ → → Multi-length - No Reel - **CE**

BSPB	BSPT	NPT	DESCRIPTION
<b>24H980</b>	<b>24H984</b>	<b>24H976</b>	<b>LDM5 FLEX METER</b>
Includes:			
24G589	24G590	24G588	Universal oil pump 5:1
24H610	24H609	24H608	Fluid hose kit
16F948	16F949	16F878	PVC Down tube
24F887	24F881	255751	LDM5 manual meter with flexible extension
125041	125041	110223	2-way vented valve
24H419	24H419	24H420	Air pressure regulator
24J379	24J379	24J379	Accessory kit
<b>24H981</b>	<b>24H985</b>	<b>24H977</b>	<b>LDM5 RIGID METER</b>
Includes: idem as 24H980, 24H984, 24H976 but with			
24F888	24F882	256215	LDM5 manual meter with rigid extension
<b>24H982</b>	<b>24H986</b>	<b>24H978</b>	<b>LDP5 FLEX METER</b>
Includes: idem as 24H980, 24H984, 24H976 but with			
24F889	24F883	255277	LDP5 preset meter with flexible extension
<b>24H983</b>	<b>24H987</b>	<b>24H979</b>	<b>LDP5 RIGID METER</b>
Includes: idem as 24H980, 24H984, 24H976 but with			
24F890	24F884	256216	LDP5 preset meter with rigid extension



CE version shown



# Oil IBC Packages WITHOUT Reels

## 3:1 OIL WALL MOUNT PACKAGE

→ → → Drum size 1040L - No Meter - No Reel

BSPP	BSPT	NPT	DESCRIPTION
<b>24H696</b>	<b>24H697</b>	<b>24H695</b>	<b>NON CE</b>
Includes:			
24G577	24G578	24G576	Universal oil pump 3:1
24H861	24H860	24H859	Fluid hose kit
24H667	24H668	24H666	1260mm Down tube with 2m suction hose
24F910	24F910	24F910	Wall mount bracket
<b>24H699</b>	<b>24H700</b>	<b>24H698</b>	<b>CE</b>
Includes:			
24G577	24G578	24G576	Universal oil pump 3:1
24H610	24H609	24H608	Fluid hose kit
24H667	24H668	24H666	1260mm Down tube with 2m suction hose
24F910	24F910	24F910	Wall mount bracket
125041	125041	110223	2-Way vented valve
24H419	24H419	24H420	Air pressure regulator
24J378	24J378	24J378	Accessory kit

## 5:1 OIL WALL MOUNT PACKAGE

→ → → Drum size 1040L - No Meter - No Reel

BSPP	BSPT	NPT	DESCRIPTION
<b>24H843</b>	<b>24H844</b>	<b>24H842</b>	<b>NON CE</b>
Includes:			
24G589	24G590	24G588	Universal oil pump 5:1
24H861	24H860	24H859	Fluid hose kit
24H667	24H668	24H666	1260Mm Down tube with 2m suction hose
24F910	24F910	24F910	Wall mount bracket
<b>24H846</b>	<b>24H847</b>	<b>24H845</b>	<b>CE</b>
Includes:			
24G589	24G590	24G588	Universal oil pump 5:1
24H610	24H609	24H608	Fluid hose kit
24H667	24H668	24H666	1260mm Down tube with 2m suction hose
24F910	24F910	24F910	Wall mount bracket
125041	125041	110223	2-Way vented valve
24H419	24H419	24H420	Air pressure regulator
24J378	24J378	24J378	Accessory kit



CE version shown

# Oil IBC Packages WITH Reels

## 3:1 OIL TOP MOUNT PACKAGE

→ → → Drum Size 1040L - LD Enclosed Reel (1/2" x 11M) - **NON CE**

BSPP	BSPT	NPT	DESCRIPTION
<b>24H705</b>	<b>24H709</b>	<b>24H701</b>	<b>LDM5 FLEX METER</b>
Includes:			
24G577	24G578	24G576	Universal oil pump 3:1
24J496	24J497	24J495	Fluid hose kit
16F962	16F963	16F885	Down tube
24F930	24F930	24F930	Top mount bracket
24F932	24F932	24F932	Reel bracket kit
24F914	24F914	24F914	Meter tray
24J133	24F796	24H662	Enclosed hose reel, 1/2" x 11m
24F887	24F881	255751	LDM5 manual meter with flexible extension
<b>24H706</b>	<b>24H710</b>	<b>24H702</b>	<b>LDM5 RIGID METER</b>
Includes: Idem as 24H705, 24H710, 24H701 but with			
24F888	24F882	256215	LDM5 manual meter with rigid extension
<b>24H707</b>	<b>24H711</b>	<b>24H703</b>	<b>LDP5 FLEX METER</b>
Includes: Idem as 24H705, 24H710, 24H701 but with			
24F889	24F883	255277	LDP5 preset meter with flexible extension
<b>24H708</b>	<b>24H712</b>	<b>24H704</b>	<b>LDP5 RIGID METER</b>
Includes: Idem as 24H705, 24H710, 24H701 but with			
24F890	24F884	256216	LDP5 preset meter with rigid extension

→ → → Drum Size 1040L - LD Enclosed Reel (1/2" x 11M) - **CE**

BSPP	BSPT	NPT	DESCRIPTION
<b>24H717</b>	<b>24H721</b>	<b>24H713</b>	<b>LDM5 FLEX METER</b>
Includes:			
24G577	24G578	24G576	Universal oil pump 3:1
24J493	24J494	24J492	Fluid hose kit
16F962	16F963	16F885	Down tube
24F930	24F930	24F930	Top mount bracket
24F932	24F932	24F932	Reel bracket kit
24F914	24F914	24F914	Meter tray
24J133	24F796	24H662	Enclosed hose reel, 1/2" x 11m
24F887	24F881	255751	LDM5 manual meter with flexible extension
125041	125041	110223	2-Way vented valve
24H419	24H419	24H420	Air pressure regulator
24J378	24J378	24J378	Accessory kit
<b>24H718</b>	<b>24H722</b>	<b>24H714</b>	<b>LDM5 RIGID METER</b>
Includes: Idem as 24H717, 24H721, 24H713 but with			
24F888	24F882	256215	LDM5 manual meter with rigid extension
<b>24H719</b>	<b>24H723</b>	<b>24H715</b>	<b>LDP5 FLEX METER</b>
Includes: Idem as 24H717, 24H721, 24H713 but with			
24F889	24F883	255277	LDP5 preset meter with flexible extension
<b>24H720</b>	<b>24H724</b>	<b>24H716</b>	<b>LDP5 RIGID METER</b>
Includes: Idem as 24H717, 24H721, 24H713 but with			
24H890	24F884	256216	LDP5 Meter with rigid extension



CE version shown

## 5:1 OIL TOP MOUNT PACKAGE

→ → → Drum Size 1040L - LD Enclosed Reel (1/2" x 11m) - **NON CE**

BSPP	BSPT	NPT	DESCRIPTION
<b>24H871</b>	<b>24H875</b>	<b>24H867</b>	<b>LDM5 FLEX METER</b>
Includes:			
24G589	24G590	24G588	Universal oil pump 5:1
24J496	24J497	24J495	Fluid hose kit
16F962	16F963	16F885	Down tube
24F930	24F930	24F930	Top mount bracket
24F932	24F932	24F932	Reel bracket kit
24F914	24F914	24F914	Meter tray
24J133	24F796	24H662	Enclosed hose reel, 1/2" x 11m
24F887	24F881	255751	LDM5 manual meter with flexible extension
<b>24H872</b>	<b>24H876</b>	<b>24H868</b>	<b>LDM5 RIGID METER</b>
Includes: Idem as 24H705, 24H710, 24H701 but with			
24F888	24F882	256215	LDM5 manual meter with rigid extension
<b>24H873</b>	<b>24H877</b>	<b>24H869</b>	<b>LDP5 FLEX METER</b>
Includes: Idem as 24H705, 24H710, 24H701 but with			
24F889	24F883	255277	LDP5 preset meter with flexible extension
<b>24H874</b>	<b>24H878</b>	<b>24H870</b>	<b>LDP5 RIGID METER</b>
Includes: Idem as 24H705, 24H710, 24H701 but with			
24F890	24F884	256216	LDP5 preset meter with rigid extension

→ → → Drum Size 1040L - LD Enclosed Reel (1/2" x 11m) - **CE**

BSPP	BSPT	NPT	DESCRIPTION
<b>24H883</b>	<b>24H887</b>	<b>24H879</b>	<b>LDM5 FLEX METER</b>
Includes:			
24G589	24G590	24G588	Universal oil pump 5:1
24J493	24J494	24J492	Fluid hose kit
16F962	16F963	16F885	Down tube
24F930	24F930	24F930	Top mount bracket
24F932	24F932	24F932	Reel bracket kit
24F914	24F914	24F914	Meter tray
24J133	24F796	24H662	Enclosed hose reel, 1/2" x 11m
24F887	24F881	255751	LDM5 manual meter with flexible extension
125041	125041	110223	2-Way vented valve
24H419	24H419	24H420	Air pressure regulator
24J378	24J378	24J378	Accessory kit
<b>24H884</b>	<b>24H888</b>	<b>24H880</b>	<b>LDM5 RIGID METER</b>
Includes: Idem as 24H883, 24H887, 24H879 but with			
24F888	24F882	256215	LDM5 manual meter with rigid extension
<b>24H885</b>	<b>24H889</b>	<b>24H881</b>	<b>LDM5 FLEX METER</b>
Includes: Idem as 24H883, 24H887, 24H879 but with			
24F889	24F883	255277	LDP5 preset meter with flexible extension
<b>24H886</b>	<b>24H890</b>	<b>24H882</b>	<b>LDM5 RIGID METER</b>
Includes: Idem as 24H883, 24H887, 24H879 but with			
24F890	24F884	256216	LDP5 preset meter with rigid extension



CE version shown

### 3:1 OIL SIDE MOUNT PACKAGE

→ → → Drum Size 1040L - LD Enclosed Reel (1/2" x 11M) - **NON CE**

BSPB	BSPT	NPT	DESCRIPTION
<b>24H729</b>	<b>24H733</b>	<b>24H725</b>	<b>LDM5 FLEX METER</b>
Includes:			
24G577	24G578	24G576	Universal oil pump 3:1
24J496	24J497	24J495	Fluid hose kit
24H670	24H671	24H669	Suction hose kit
24F920	24F920	24F920	Pump bracket
24F931	24F931	24F931	Top mount bracket
24F932	24F932	24F932	Reel bracket kit
24F914	24F914	24F914	Meter tray
24J133	24F796	24H662	Enclosed hose reel, 1/2" x 11m
24F887	24F881	255751	LDM5 manual meter with flexible extension
<b>24H730</b>	<b>24H734</b>	<b>24H726</b>	<b>LDM5 RIGID METER</b>
Includes: Idem as 24H729, 24H733, 24H725 but with			
24F888	24F882	256215	LDM5 manual meter with rigid extension
<b>24H731</b>	<b>24H735</b>	<b>24H727</b>	<b>LDP5 FLEX METER</b>
Includes: Idem as 24H729, 24H733, 24H725 but with			
24F889	24F883	255277	LDP5 preset meter with flexible extension
<b>24H732</b>	<b>24H736</b>	<b>24H728</b>	<b>LDP5 RIGID METER</b>
Includes: Idem as 24H729, 24H733, 24H725 but with			
24F890	24F884	256216	LDP5 preset meter with rigid extension

→ → → Drum Size 1040L - LD Enclosed Reel (1/2" x 11M) - **CE**

BSPB	BSPT	NPT	DESCRIPTION
<b>24H741</b>	<b>24H745</b>	<b>24H737</b>	<b>LDM5 FLEX METER</b>
Includes:			
24G577	24G578	24G576	Universal oil pump 3:1
24J493	24J492	24J493	Fluid hose kit
24H670	24H671	24H669	Suction hose kit
24F920	24F920	24F920	Pump bracket
24F931	24F931	24F931	Top mount bracket
24F932	24F932	24F932	Reel bracket kit
24F914	24F914	24F914	Meter tray
24J133	24F796	24H662	Enclosed hose reel, 1/2" x 11m
24F887	24F881	255751	LDM5 manual meter with flexible extension
125041	125041	110223	2-Way vented valve
24H419	24H419	24H420	Air pressure regulator
24J378	24J378	24J378	Accessory kit
<b>24H742</b>	<b>24H746</b>	<b>24H738</b>	<b>LDM5 RIGID METER</b>
Includes: Idem as 24H741, 24H745, 24H737 but with			
24F888	24F882	256215	LDM5 manual meter with rigid extension
<b>24H743</b>	<b>24H747</b>	<b>24H739</b>	<b>LDP5 FLEX METER</b>
Includes: Idem as 24H741, 24H745, 24H737 but with			
24F889	24F883	255277	LDP5 preset meter with flexible extension
<b>24H744</b>	<b>24H748</b>	<b>24H740</b>	<b>LDP5 RIGID METER</b>
Includes: Idem as 24H741, 24H745, 24H737 but with			
24F890	24F884	256216	LDP5 preset meter with rigid extension



CE version shown



## 5:1 OIL SIDE MOUNT PACKAGE

→ → → Drum Size 1040L - LD Enclosed Reel (1/2" x 11m) - **NON CE**

BSPP	BSPT	NPT	DESCRIPTION
<b>24H895</b>	<b>24H899</b>	<b>24H891</b>	<b>LDM5 FLEX METER</b>
Includes:			
24G589	24G590	24G588	Universal oil pump 5:1
24J496	24J497	24J495	Fluid hose kit
24H670	24H671	24H669	Suction hose kit
24F920	24F920	24F920	Pump bracket
24F931	24F931	24F931	Top mount bracket
24F932	24F932	24F932	Reel bracket kit
24F914	24F914	24F914	Meter tray
24J133	24F796	24H662	Enclosed hose reel, 1/2" x 11m
24F887	24F881	255751	LDM5 manual meter with flexible extension
<b>24H896</b>	<b>24H900</b>	<b>24H892</b>	<b>LDM5 RIGID METER</b>
Includes: idem as 24H729, 24H733, 24H725 but with			
24F888	24F882	256215	LDM5 manual meter with rigid extension
<b>24H897</b>	<b>24H901</b>	<b>24H893</b>	<b>LDP5 FLEX METER</b>
Includes: idem as 24H729, 24H733, 24H725 but with			
24F889	24F883	255277	LDP5 preset meter with flexible extension
<b>24H898</b>	<b>24H902</b>	<b>24H894</b>	<b>LDP5 RIGID METER</b>
Includes: idem as 24H729, 24H733, 24H725 but with			
24F890	24F884	256216	LDP5 preset meter with rigid extension

→ → → Drum Size 1040L - LD Enclosed Reel (1/2" x 11m) - **CE**

BSPP	BSPT	NPT	DESCRIPTION
<b>24H907</b>	<b>24H911</b>	<b>24H903</b>	<b>LDM5 FLEX METER</b>
Includes:			
24G589	24G590	24G588	Universal oil pump 5:1
24J493	24J494	24J492	Fluid hose kit
24H670	24H671	24H669	Suction hose kit
24F920	24F920	24F920	Pump bracket
24F931	24F931	24F931	Top mount bracket
24F932	24F932	24F932	Reel bracket kit
24F914	24F914	24F914	Meter tray
24J133	24F796	24H662	Enclosed hose reel, 1/2" x 11m
24F887	24F881	255751	LDM5 manual meter with flexible extension
125041	125041	110223	2-way vented valve
24H419	24H419	24H420	Air pressure regulator
24J378	24J378	24J378	Accessory kit
<b>24H908</b>	<b>24H912</b>	<b>24H904</b>	<b>LDM5 RIGID METER</b>
Includes: idem as 24H741, 24H745, 24H737 but with			
24F888	24F882	256215	LDM5 manual meter with rigid extension
<b>24H909</b>	<b>24H913</b>	<b>24H905</b>	<b>LDP5 FLEX METER</b>
Includes: idem as 24H741, 24H745, 24H737 but with			
24F889	24F883	255277	LDP5 preset meter with flexible extension
<b>24H910</b>	<b>24H914</b>	<b>24H906</b>	<b>LDP5 RIGID METER</b>
Includes: idem as 24H907, 24H911, 24H903 but with			
24F890	24F884	256216	LDP5 preset meter with rigid extension



CE version shown

# Oil Cart Mount Packages WITHOUT Reels

## 3:1 OIL CART MOUNT PACKAGES

→ → → No Reel - NON CE

BSPP	BSPT	NPT	DESCRIPTION
<b>24H778</b>	<b>24H782</b>	<b>24H774</b>	<b>LDM5 FLEX METER</b>
Includes:			
24G577	24G578	24G576	Universal oil pump 3:1
24J496	24J497	24J495	Fluid hose kit
16F950	16F951	16F886	Metal Down tube
24F915	24F915	24F915	Cart
24F887	24F881	255751	LDM5 manual meter with flexible extension
<b>24H779</b>	<b>24H783</b>	<b>24H775</b>	<b>LDM5 RIGID METER</b>
Includes: Idem as 24H778, 24H782, 24H774 but with			
24F888	24F882	256215	LDM5 manual meter with rigid extension
<b>24H780</b>	<b>24H784</b>	<b>24H776</b>	<b>LDP5 FLEX METER</b>
Includes Idem as 24H778, 24H782, 24H774 but with			
24F889	24F883	255277	LDP5 preset meter with flexible extension
<b>24H781</b>	<b>24H785</b>	<b>24H777</b>	<b>LDP5 RIGID METER</b>
Includes: Idem as 24H778, 24H782, 24H774 but with			
24F890	24F884	256216	LDP5 preset meter with rigid extension

→ → → No Reel - CE

BSPP	BSPT	NPT	DESCRIPTION
<b>24H790</b>	<b>24H794</b>	<b>24H786</b>	<b>LDM5 FLEX METER</b>
Includes:			
24G577	24G578	24G576	Universal oil pump 3:1
24J493	24J494	24J492	Fluid hose kit
16F950	16F951	16F886	Metal Down tube
24F915	24F915	24F915	Cart
24F887	24F881	255751	LDM5 manual meter with flexible extension
125041	125041	110223	2-Way vented valve
24H419	24H419	24H420	Air pressure regulator
24J378	24J378	24J378	Accessory kit
<b>24H791</b>	<b>24H795</b>	<b>24H787</b>	<b>LDM5 RIGID METER</b>
Includes: Idem as 24H790, 24H794, 24H786 but with			
24F888	24F882	256215	LDM5 manual meter with rigid extension
<b>24H792</b>	<b>24H796</b>	<b>24H788</b>	<b>LDP5 FLEX METER</b>
Includes: Idem as 24H790, 24H794, 24H786 but with			
24F889	24F883	255277	LDP5 preset meter with flexible extension
<b>24H793</b>	<b>24H797</b>	<b>24H789</b>	<b>LDP5 RIGID METER</b>
Includes: Idem as 24H790, 24H794, 24H786 but with			
24F890	24F884	256216	LDP5 preset meter with rigid extension



CE version shown

## 5:1 OIL CART MOUNT PACKAGES

→ → → No Reel - NON CE

BSPP	BSPT	NPT	DESCRIPTION
<b>24H944</b>	<b>24H948</b>	<b>24H940</b>	<b>LDM5 FLEX METER</b>
Includes:			
24G589	24G590	24G588	Universal oil pump 5:1
24J496	24J497	24J495	Fluid hose kit
16F950	16F951	16F886	Metal Down tube
24F915	24F915	24F915	Cart
24F887	24F881	255751	LDM5 manual meter with flexible extension
<b>24H945</b>	<b>24H949</b>	<b>24H941</b>	<b>LDM5 RIGID METER</b>
Includes: Idem as 24H944, 24H948, 24H940 but with			
24F888	24F882	256215	LDM5 manual meter with rigid extension
<b>24H946</b>	<b>24H950</b>	<b>24H942</b>	<b>LDP5 FLEX METER</b>
Includes: Idem as 24H944, 24H948, 24H940 but with			
24F889	24F883	255277	LDP5 preset meter with flexible extension
<b>24H947</b>	<b>24H951</b>	<b>24H943</b>	<b>LDP5 RIGID METER</b>
Includes: Idem as 24H944, 24H948, 24H940 but with			
24F890	24F884	256216	LDP5 preset meter with rigid extension

→ → → No Reel - CE

BSPP	BSPT	NPT	DESCRIPTION
<b>24H956</b>	<b>24H960</b>	<b>24H952</b>	<b>LDM5 FLEX METER</b>
Includes:			
24G589	24G590	24G588	Universal oil pump 5:1
24J493	24J494	24J492	Fluid hose kit
16F950	16F951	16F886	Metal Down tube
24F915	24F915	24F915	Cart
24F887	24F881	255751	LDM5 manual meter with flexible extension
125041	125041	110223	2-Way vented valve
24H419	24H419	24H420	Air pressure regulator
24J378	24J378	24J378	Accessory kit
<b>24H957</b>	<b>24H961</b>	<b>24H953</b>	<b>LDM5 RIGID METER</b>
Includes: Idem as 24H956, 24H960, 24H952 but with			
24F888	24F882	256215	LDM5 manual meter with rigid extension
<b>24H958</b>	<b>24H962</b>	<b>24H954</b>	<b>LDP5 FLEX METER</b>
Includes: Idem as 24H790, 24H794, 24H786 but with			
24F889	24F883	255277	LDP5 preset meter with flexible extension
<b>24H959</b>	<b>24H963</b>	<b>24H955</b>	<b>LDP5 RIGID METER</b>
Includes: Idem as 24H790, 24H794, 24H786 but with			
24F890	24F884	256216	LDP5 preset meter with rigid extension



CE version shown

# Oil Cart Mount Packages WITH Reels

## 3:1 OIL CART MOUNT PACKAGES

→ → → LD Enclosed Reel (1/2" x 11M) - **NON CE**

BSPP	BSPT	NPT	DESCRIPTION
<b>24H754</b>	<b>24H758</b>	<b>24H750</b>	<b>LDM5 FLEX METER</b>
Includes:			
24G577	24G578	24G576	Universal oil pump 3:1
24J496	24J495	24J497	Fluid hose kit
16F950	16F951	16F886	Metal Down tube
24F915	24F915	24F915	Cart
24J133	24F796	24H662	Enclosed hose reel, 1/2" x 11m
24F887	24F881	255751	LDM5 manual meter with flexible extension
<b>24H755</b>	<b>24H759</b>	<b>24H751</b>	<b>LDM5 RIGID METER</b>
Includes: Idem as 24H755, 24H759, 24H751 but with			
24F888	24F882	256215	LDM5 manual meter with rigid extension
<b>24H756</b>	<b>24H760</b>	<b>24H752</b>	<b>LDP5 FLEX METER</b>
Includes:			
Idem as 24H755, 24H759, 24H751 but with			
24F889	24F883	255277	LDP5 preset meter with flexible extension
<b>24H757</b>	<b>24H761</b>	<b>24H753</b>	<b>LDP5 RIGID METER</b>
Includes: Idem as 24H755, 24H759, 24H751 but with			
24F890	24F884	256216	LDP5 preset meter with rigid extension

→ → → LD Enclosed Reel (1/2" x 11M) - **CE**

BSPP	BSPT	NPT	DESCRIPTION
<b>24H766</b>	<b>24H770</b>	<b>24H762</b>	<b>LDM5 FLEX METER</b>
Includes:			
24G577	24G578	24G576	Universal oil pump 3:1
24J493	24J494	24J492	Fluid hose kit
16F950	16F951	16F886	Metal Down tube
24F915	24F915	24F915	Cart
24J133	24F796	24H662	Enclosed hose reel, 1/2" x 11m
24F887	24F881	255751	LDM5 manual meter with flexible extension
125041	125041	110223	2-Way vented valve
24H419	24H419	24H420	Air pressure regulator
24J378	24J378	24J378	Accessory kit
<b>24H767</b>	<b>24H771</b>	<b>24H763</b>	<b>LDM5 RIGI METER</b>
Includes:			
Idem as 24H766, 24H770, 24H762 but with			
24F888	24F882	256215	LDM5 manual meter with rigid extension
<b>24H768</b>	<b>24H772</b>	<b>24H764</b>	<b>LDP5 FLEX METER</b>
Includes:			
Idem as 24H755, 24H759, 24H751 but with			
24F889	24F883	255277	LDP5 preset meter with flexible extension
<b>24H769</b>	<b>24H773</b>	<b>24H765</b>	<b>LDP5 RIGID METER</b>
Includes:			
Idem as 24H766, 24H770, 24H762 but with			
24F890	24F884	256216	LDP5 preset meter with rigid extension



CE version shown



## 5:1 OIL CART MOUNT PACKAGES

→ → → Enrouleur de flexible carrossé LD (1/2" x 11m) - **NON CE**

BSPP	BSPT	NPT	DESCRIPTION
<b>24H919</b>	<b>24H923</b>	<b>24H915</b>	<b>VOLUCOMPTEUR FLEX LDM5</b>
Includes:			
24G589	24G590	24G588	Universal oil pump 5:1
24J496	24J497	24J495	Fluid hose kit
16F950	16F951	16F886	Metal Down tube
24F915	24F915	24F915	Cart
24J133	24F796	24H662	Enclosed hose reel, 1/2" x 11m
24F887	24F881	255751	LDM5 manual meter with flexible extension
<b>24H920</b>	<b>24H924</b>	<b>24H916</b>	<b>LDM5 RIGID METER</b>
Includes: Idem as 24H919, 24H923, 24H915 but with			
24F888	24F882	256215	LDM5 manual meter with rigid extension
<b>24H921</b>	<b>24H925</b>	<b>24H917</b>	<b>LDP5 FLEX METER</b>
Includes: Idem as 24H919, 24H923, 24H915 but with			
24F889	24F883	255277	LDP5 preset meter with flexible extension
<b>24H922</b>	<b>24H926</b>	<b>24H918</b>	<b>LDP5 RIGID METER</b>
Includes: Idem as 24H919, 24H923, 24H915 but with			
24F890	24F884	256216	LDP5 preset meter with rigid extension

→ → → LD Enclosed Reel (1/2" x 11m) - **CE**

BSPP	BSPT	NPT	DESCRIPTION
<b>24H931</b>	<b>24H935</b>	<b>24H927</b>	<b>LDM5 FLEX METER</b>
Includes:			
24G589	24G590	24G588	Universal oil pump 5:1
24J493	24J494	24J492	Fluid hose kit
16F950	16F951	16F886	Metal Down tube
24F915	24F915	24F915	Cart
24J133	24F796	24H662	Enclosed hose reel, 1/2" x 11m
24F887	24F881	255751	LDM5 manual meter with flexible extension
125041	125041	110223	2-Way vented valve
24H419	24H419	24H420	Air pressure regulator
24J378	24J378	24J378	Accessory kit
<b>24H932</b>	<b>24H936</b>	<b>24H928</b>	<b>LDM5 RIGID METER</b>
Includes: Idem as 24H931, 24H935, 24H927 but with			
24F888	24F882	256215	LDM5 manual meter with rigid extension
<b>24H933</b>	<b>24H937</b>	<b>24H929</b>	<b>LDP5 FLEX METER</b>
Includes: Idem as 24H931, 24H935, 24H927 but with			
24F889	24F883	255277	LDP5 preset meter with flexible extension
<b>24H934</b>	<b>24H938</b>	<b>24H930</b>	<b>LDP5 RIGID METER</b>
Includes: Idem as 24H931, 24H935, 24H927 but with			
24F890	24F884	256216	LDP5 preset meter with rigid extension



CE version shown

# Grease Pumps and Packages

## BARE GREASE PUMPS

BSPP	BSPT	NPT	DESCRIPTION
24G601	24G602	24G600	LD Pump, 50:1 - 16kg/20kg
24G604	24G605	24G603	LD Pump, 50:1 - 55kg/60kg
24G607	24G608	24G606	LD Pump, 50:1 - 180kg



## 50:1 GREASE DRUM PACKAGES 10-40KG

BSPP	BSPT	NPT	DESCRIPTION
<b>24R345</b>	<b>24R346</b>	<b>24R344</b>	<b>GREASE DRUM PACKAGE</b>
24G601	24G602	24G600	Grease pump 50:1
24H674	24H673	24H672	Fluid hose kit
24H404	24H400	242056	Grease valve
24H615	24H614	202577	Z-swivel
125041	125041	110223	2-way vented valve
24H419	24H419	24H420	Air pressure regulator
24J377	24J377	24J377	Accessory kit
24P623	24P623	24P623	Flexible bung adapter
24N921	24N921	24N921	Drum cover small 10-30kg, diameter 295 mm

BSPP	BSPT	NPT	DESCRIPTION
<b>24J034</b>	<b>24J035</b>	<b>24J033</b>	<b>GREASE DRUM PACKAGE</b>
24G601	24G602	24G600	Grease pump 50:1
24H674	24H673	24H672	Fluid hose kit
24H404	24H400	242056	Grease valve
24H615	24H614	202577	Z-swivel
125041	125041	110223	2-way vented valve
24H419	24H419	24H420	Air pressure regulator
24J377	24J377	24J377	Accessory kit
24P623	24P623	24P623	Flexible bung adapter
24F904	24F904	24F904	Drum cover medium and large 10-40 kg, diameter 322 mm



BSPP	BSPT	NPT	DESCRIPTION
<b>24R348</b>	<b>24R349</b>	<b>24R347</b>	<b>GREASE DRUM PACKAGE</b>
24G601	24G602	24G600	Grease pump 50:1
24H674	24H673	24H672	Fluid hose kit
24H404	24H400	242056	Grease valve
24H615	24H614	202577	Z-swivel
125041	125041	110223	2-way vented valve
24H419	24H419	24H420	Air pressure regulator
24J377	24J377	24J377	Accessory kit
24P623	24P623	24P623	Flexible bung adapter
24N922	24N922	24N922	Drum cover 10-40kg, diameter 340 mm

## FOLLOWER PLATES

24N926	Follower plate small 12-18kg, plate 200 mm/wiper 290 mm*
24P255	Follower plate medium 12-18kg, plate 200 mm/ wiper 312,5 mm*
24N927	Follower plate large 12-18kg, plate 245 mm/ wiper 320 mm*
24N928	Follower plate 20 kg, plate 245 mm/ wiper 345*
24F901	Follower plate 40 lb (U.S. style drums)

\* Plate 25-38 clearance per side / Wiper 2,5-19 mm interference per side



## 50:1 GREASE DRUM PACKAGES 30-110KG

BSPP	BSPT	NPT	DESCRIPTION
<b>24R354</b>	<b>24R355</b>	<b>24R353</b>	<b>GREASE DRUM PACKAGE</b>
24G604	24G605	24G603	Grease pump 50:1
24H674	24H673	24H672	Fluid hose kit
24H404	24H400	242056	Grease valve
24H615	24H614	202577	Z-swivel
125041	125041	110223	2-way vented valve
24H419	24H419	24H420	Air pressure regulator
24J377	24J377	24J377	Accessory kit
24P623	24P623	24P623	Flexible bung adapter
24F905	24F905	24F905	Drum cover 30-70 kg, diameter 389 mm



BSPP	BSPT	NPT	DESCRIPTION
<b>24J040</b>	<b>24J041</b>	<b>24J039</b>	<b>GREASE DRUM PACKAGE</b>
24G604	24G605	24G603	Grease pump 50:1
24H674	24H673	24H672	Fluid hose kit
24H404	24H400	242056	Grease valve
24H615	24H614	202577	Z-swivel
125041	125041	110223	2-way vented valve
24H419	24H419	24H420	Air pressure regulator
24J377	24J377	24J377	Accessory kit
24P623	24P623	24P623	Flexible bung adapter
24N924	24N924	24N924	Drum cover 50-110 kg, diameter 450 mm

## 50:1 GREASE CART MOUNT PACKAGES - NO REEL

BSPP	BSPT	NPT	DESCRIPTION
<b>24R357</b>	<b>24R358</b>	<b>24R356</b>	<b>GREASE CART MOUNT PACKAGE</b>
Includes:			
24G604	24G605	24G603	Grease pump 50:1
24H674	24H673	24H672	Fluid hose kit
24H404	24H400	242056	Grease valve
24H615	24H614	202577	Z-swivel
125041	125041	110223	2-way vented valve
24H419	24H419	24H420	Air pressure regulator
24J377	24J377	24J377	Accessory kit
24P623	24P623	24P623	Flexible bung adapter
24F905	24F905	24F905	Drum cover 30-70 kg, diameter 389 mm
24H422	24H422	24H422	Cart



BSPB	BSPT	NPT	DESCRIPTION
<b>24J052</b>	<b>24J053</b>	<b>24J051</b>	<b>GREASE CART MOUNT PACKAGE</b>
Includes:			
24G604	24G605	24G603	Grease pump 50:1
24J499	24J500	24J498	Fluid hose kit
24H404	24H400	242056	Grease valve
24H615	24H614	202577	Z-swivel
125041	125041	110223	2-way vented valve
24H419	24H419	24H420	Air pressure regulator
24J377	24J377	24J377	Accessory kit
24P623	24P623	24P623	Flexible bung adapter
24N924	24N924	24N924	Drum cover 50-110 kg, diameter 450 mm
24H422	24H422	24H422	Cart

BSPB	BSPT	NPT	DESCRIPTION
<b>24R360</b>	<b>24R361</b>	<b>24R359</b>	<b>GREASE CART MOUNT PACKAGE WITH REEL</b>
Includes:			
24G604	24G605	24G603	Grease pump 50:1
24J499	24J500	24J498	Fluid hose kit
24H404	24H400	242056	Grease valve
24H615	24H614	202577	Z-swivel
125041	125041	110223	2-way vented valve
24H419	24H419	24H420	Air pressure regulator
24J377	24J377	24J377	Accessory kit
24P623	24P623	24P623	Flexible bung adapter
24F905	24F905	24F905	Drum cover 30-70 kg, diameter 389 mm
24H422	24H422	24H422	Cart
24J134	24F797	24H663	Hose reel (1/4" x 11m)



BSPB	BSPT	NPT	DESCRIPTION
<b>24J064</b>	<b>24J065</b>	<b>24J063</b>	<b>GREASE CART MOUNT PACKAGE WITH REEL</b>
Includes:			
24G604	24G605	24G603	Grease pump 50:1
24J499	24J500	24J498	Fluid hose kit
24H404	24H400	242056	Grease valve
24H615	24H614	202577	Z-swivel
125041	125041	110223	2-way vented valve
24H419	24H419	24H420	Air pressure regulator
24J377	24J377	24J377	Accessory kit
24P623	24P623	24P623	Flexible bung adapter
24N924	24N924	24N924	Drum cover 50-110 kg, diameter 450 mm
24H422	24H422	24H422	Cart
24J134	24F797	24H663	Hose reel (1/4" x 11m)

FOLLOWER PLATES	
24N929	Follower plate 50 kg, plate 310 mm/ wiper 375 mm*
24N930	Follower plate 50 kg, plate 329 mm/ wiper 410 mm*
24F902	Follower plate 120 lb (U.S. style drums)



\* Plate 25-38 clearance per side / Wiper 2,5-19 mm interference per side

## 50:1 GREASE DRUM PACKAGES 180KG

BSPP	BSPT	NPT	DESCRIPTION
<b>24J046</b>	<b>24J047</b>	<b>24J045</b>	<b>GREASE DRUM PACKAGE</b>
Includes:			
24G607	24G608	24G606	Grease pump 50:1
24H674	24H673	24H672	Fluid hose kit
24H404	24H400	242056	Grease valve
24H615	24H614	202577	Z-swivel
125041	125041	110223	2-way vented valve
24H419	24H419	24H420	Air pressure regulator
24J377	24J377	24J377	Accessory kit
24P623	24P623	24P623	Flexible bung adapter
24F906	24F906	24F906	Drum cover 180 kg



BSPP	BSPT	NPT	DESCRIPTION
<b>24J058</b>	<b>24J059</b>	<b>24J057</b>	<b>GREASE CART MOUNT PACKAGE</b>
Includes:			
24G607	24G608	24G606	Grease pump 50:1
24H674	24H673	24H672	Fluid hose kit
24H404	24H400	242056	Grease valve
24H615	24H614	202577	Z-swivel
125041	125041	110223	2-way vented valve
24H419	24H419	24H420	Air pressure regulator
24J377	24J377	24J377	Accessory kit
24P623	24P623	24P623	Flexible bung adapter
24F906	24F906	24F906	Drum cover 180 kg
24F915	24F915	24F915	Cart
24J134	24F797	24H663	Hose reel (1/4" x 11m)



BSPP	BSPT	NPT	DESCRIPTION
<b>24J070</b>	<b>24J071</b>	<b>24J069</b>	<b>GREASE CART MOUNT PACKAGE WITH REEL</b>
Includes:			
24G607	24G608	24G606	Grease pump 50:1
24H674	24H673	24H672	Fluid hose kit
24H404	24H400	242056	Grease valve
24H615	24H614	202577	Z-swivel
125041	125041	110223	2-way vented valve
24H419	24H419	24H420	Air pressure regulator
24J377	24J377	24J377	Accessory kit
24P623	24P623	24P623	Flexible bung adapter
24F906	24F906	24F906	Drum cover 180 kg
24F915	24F915	24F915	Cart
24J134	24F797	24H663	Hose reel (1/4" x 11m)



## FOLLOWER PLATES

24F903	24F903	24F903	Follower plate 180 kg
--------	--------	--------	-----------------------





# Accessories LD Packages

BSPP	BSPT	NPT	DESCRIPTION
<b>SUCTION KITS</b>			
24F936	24F937	24F935	LD oil pump suction hose kit for 200L drum - incl. bung adapter, foot valve and 1,8m suction hose
24H667	24H668	24H666	LD oil pump suction hose kit for 1040L IBC - incl. bung adapter, foot valve and 1,8m suction hose
24H670	24H671	24H669	LD Oil Pump Suction hose kit and adapter for mounting pump to the side of IBC tote and dispensing from drain - incl. suction hose, elbow fitting and union fitting

BSPP	BSPT	NPT	DESCRIPTION
<b>HOSE AND FITTING KITS - OIL (NON CE)</b>			
24J095	24H866	24H865	4,5m LD pump fluid hose kit. Includes 1/2" x 4,5m fluid hose, 3/8" x 1,8m Air hose, swivel (157705), and union fitting (156684)
24H861	24H860	24H859	1,8m LD pump fluid hose kit. Includes 1/2" x 1,8m fluid hose, 3/8" x 1,8m Air hose, Swivel (157705), and union fitting (156684)

BSPP	BSPT	NPT	DESCRIPTION
<b>HOSE AND FITTING KITS - OIL (CE)</b>			
24H835	24H834	24H833	4,5m LD pump fluid hose kit. Includes 1/2" x 4,5m fluid hose, 3/8" x 1,8m Air hose, swivel (157705), and union fitting (156684)
24H610	24H609	24H608	1,8m LD pump fluid hose kit. Includes 1/2" x 1,8m fluid hose, 3/8" x 1,8m Air hose, Swivel (157705), and union fitting (156684)

BSPP	BSPT	NPT	DESCRIPTION
<b>TOTE MOUNT ACCESSORIES</b>			
24F914	24F914	24F914	Meter drip tray for mounting to the side of IBC tote
24F932	24F932	24F932	LD Reel bracket for mounting reel to IBC top mount tote bracket (24F930 & 24F920)
24F920	24F920	24F920	Tote mounting bracket to mount reel on top of IBC tote. *Pump mounting bracket is not included.
24F930	24F930	24F930	Top of tote mounting bracket. For mounting LD pump in top of IBC tote.
24F931	24F931	24F931	Bracket for mounting LD pump on the side of IBC tote



BSPP	BSPT	NPT	DESCRIPTION
<b>CARTS</b>			
24F915	24F915	24F915	Drum cart with pneumatic wheels for 180kg drums. Includes chain for securing drum to cart.
24H422	24H422	24H422	Drum cart with pneumatic wheels for 55kg drums. Includes chain for securing drum to cart.



BSPP	BSPT	NPT	DESCRIPTION
<b>HOSE AND FITTING KITS - GREASE (NON CE)</b>			
24H864	24H863	24H862	1,8m LD pump grease hose kit. Includes 1/4" x 1,8m fluid hose, 3/8" x 1,8m Air hose, and fittings

BSPP	BSPT	NPT	DESCRIPTION
<b>HOSE AND FITTING KITS - GREASE (CE)</b>			
24H674	24H673	24H672	1,8m LD pump grease hose kit. Includes 1/4" x 1,8m fluid hose, 3/8" x 1,8m Air hose, and fittings

BSPP	BSPT	NPT	DESCRIPTION
<b>MOUNTING HARDWARE</b>			
24F910	24F910	24F910	LD pump wall mounting bracket. For use with LD 3:1 & 5:1 pumps.

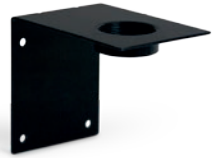

BSPP	BSPT	NPT	DESCRIPTION
<b>BUNG ADAPTER</b>			
24F918	24F918	24F918	Bung adapter for LD 3:1 & 5:1 pumps
24P623	24P623	24P623	Flexible bung adapter for 50:1 pumps grease pumps



## ABOUT GRACO

Founded in 1926, Graco is a world leader in fluid handling systems and components. Graco products move, measure, control, dispense and apply a wide range of fluids and viscous materials used in vehicle lubrication, commercial and industrial settings.

The company's success is based on its unwavering commitment to technical excellence, world-class manufacturing and unparalleled customer service. Working closely with qualified distributors, Graco offers systems, products and technology that set the quality standard in a wide range of fluid handling solutions. Graco provides equipment for spray finishing, protective coating, paint circulation, lubrication, and dispensing sealants and adhesives, along with power application equipment for the contractor industry. Graco's ongoing investment in fluid management and control will continue to provide innovative solutions to a diverse global market.

## GRACO LOCATIONS

### MAILING ADDRESS

P.O. Box 1441  
Minneapolis, MN 55440-1441  
Tel: 612-623-6000  
Fax: 612-623-6777

### AMERICAS

#### MINNESOTA

Worldwide Headquarters  
Graco Inc.  
88-11th Avenue N.E.  
Minneapolis, MN 55413

### EUROPE

#### BELGIUM

European Headquarters  
Graco BVBA  
Industrieterrein-Oude Bunders  
Slakweidestraat 31  
3630 Maasmechelen,  
Belgium  
Tel: 32 89 770 700  
Fax: 32 89 770 777

### ASIA PACIFIC

#### AUSTRALIA

Graco Australia Pty Ltd.  
Suite 17, 2 Enterprise Drive  
Bundoora, Victoria 3083  
Australia  
Tel: 61 3 9468 8500  
Fax: 61 3 9468 8599

#### CHINA

Graco Hong Kong Ltd.  
Shanghai Representative Office  
Building 7  
1029 Zhongshan Road South  
Huangpu District  
Shanghai 200011  
The People's Republic of China  
Tel: 86 21 649 50088  
Fax: 86 21 649 50077

### INDIA

Graco Hong Kong Ltd.  
India Liaison Office  
Room 432, Augusta Point  
Regus Business Centre 53  
Golf Course Road  
Gurgaon, Haryana  
India 122001  
Tel: 91 124 435 4208  
Fax: 91 124 435 4001

#### JAPAN

Graco K.K.  
1-27-12 Hayabuchi  
Tsuzuki-ku  
Yokohama City, Japan 2240025  
Tel: 81 45 593 7300  
Fax: 81 45 593 7301

#### KOREA

Graco Korea Inc.  
Shinhan Bank Building  
4th Floor #1599  
Gwanyang-Dong, Dongan-Ku,  
Anyang-si, Korea 431-060  
Tel: 82 31 476 9400  
Fax: 82 31 476 9801

All written and visual data contained in this document are based on the latest product information available at the time of publication. Graco reserves the right to make changes at any time without notice.

Graco is certified ISO 9001.

Europe  
+32 89 770 700  
FAX +32 89 770 777  
WWW.GRACO.COM

Authorized Distributor:

### Stavanger Korrosjon AS

Strandbakken 3, Dusavik Base  
4072 Randaberg  
Norway  
Phone +47 51 41 07 11  
post@stavanger-korrosjon.no  
www.stavanger-korrosjon.no

©2013 Graco BVBA 340899E Rev. B 07/13 Printed in Europe.  
All other brand names or marks are used for identification purposes and are trademarks of their respective owners.